



Natural Smoke and Heat Exhaust Ventilation Systems



Why extraction systems are necessary

Most victims of fires are killed not by the fire itself, but by the smoke. The smoke created by a fire can fill whole rooms and areas of buildings within minutes and quickly becomes a death trap. Not only do people in these situations suffer from serious smoke inhalation, but the smoke also greatly reduces visibility, making it more difficult for them to escape from the danger zone in time. On top of the loss of orientation caused by the lack of visibility comes the impairment of the senses caused by toxic fumes.

In order to prevent this, natural smoke and heat exhaust ventilation systems channel the smoke through the roof of the building before it can cool down and sink back down to the floor. The resulting smoke-free zone provides not only the air essential to allow people to breathe, but also makes it possible for them to get their bearings and helps to avoid panic. Moreover, it is thus easier for the fire brigade to quickly localise and extinguish the source of the fire.



Tested and certified systems

As natural smoke and heat exhaust ventilation systems (NSHEVs) are intended to save lives in emergency situations, there can be no compromises with regard to their operational reliability. E.M.B. Products AG supplies high-quality certified smoke and heat ventilation systems that are guaranteed to be in good working order even after many years of use. When it comes to important requirements such as their reliability under high wind or snow loads, our systems, which thanks to their high quality can also be employed for everyday ventilation, set new standards.

All of our NSHEV systems comply with DIN EN 12101-2.

Our NSHEV-systems are tested and certified for:

- Functional reliability up to Re 1000*
- Functional reliability at wind loads up to WL 3000*
- Functional reliability at snow loads up to SL 9040*
- Functional reliability at low ambient temperatures down to T(-15)*
- Sound insulation levels according to our specifications
- Functional reliability up to heat-exposure rating of B 300-E (300 °C / fire-resistance rating E)
- Tested by the Material Testing Authorities of North Rhine-Westphalia
- Tested by other independent testing institutes*
- Approved by VdS*

* depending on system size and model

* Find the different values of the VenturiSmoke at www.roda.de

NSHEV systems are also tested for:

- Correct operation during fatigue testing (10,000 opening cycles)
- Aerodynamically efficient opening surface
- Corrosion and aging resistance



EXAM BBG Prüf- und Zertifizier GmbH
Zertifizierungsstelle



I.F.I. Institut
Industrieraerodynamik
Institut an der
Fachhochschule Aachen

Natürlicher Rauch- und Wärmeabzugsgeräte (NRWG)
Prüfung der Standsicherheit
unter Windlast nach
EN 12101-2, Anhang F

Anschrift:
I.F.I. Institut für
Industrieraerodynamik GmbH
Welkenrathstraße 120
52074 Aachen

Prüfstellenleiter:
Dipl.-Ing Jorge Gomez

Notifizierte Prüf-, Überwachungs- und Zertifizierungsstelle Nr. 1368



Müller-BBM GmbH
Robert-Koch-Straße 11
82152 Planegg / München
Telefon +49 (89) 85602-0
Telefax +49 (89) 85602-111
www.muellerbbm.de
Eng. Philipp Meistring
Telefon +49 (89) 85602-228
p.meistring@muellerbbm.de
Februar 2011
30/2 msg/jre



Zertifikat
VdS
bescheinigt
Qualität

Auftraggeber:
Bezeichnung:
Hersteller:
Einsatz:
Öffnung:

Klasse:

Widerrufen:

Das Zertifikat umfasst ausschließlich das Qualitätsmanagementsystem in dem angegebenen Geltungsbereich.

Das Zertifikat gibt keine Auskunft über VdS-Anerkennungen von Sicherheitsfirmen, Wach- und Schutzunternehmen, Verfahren o. ä. Hierfür sind gesonderte Nachweise erforderlich.

Das Zertifikat darf nur unverändert und mit sämtlichen Anlagen verwendet werden. Während der Gültigkeit des Zertifikates muss das Qualitätsmanagementsystem der Organisation stets die Forderungen der Norm erfüllen. Dies wird durch VdS regelmäßig begutachtet.

Jegliche Werbung mit dem Zertifikat muss den Inhalt wiedergeben und darf nicht auf werbewerbsrechtliche Art und Weise erfolgen.

Zertifikats-Nr.:
S 897046

Geltungsbereich des Zertifikats:

Erzeuger:
Kategorie:
S:

Zertifizierungsgruppe:

Qualität:

Köln, 2

Schür



TGA-ZM-03-90-00

Geschäft:

MATERIALPRÜFUNGSAMT MPA NRW NORDRHEIN-WESTFALEN
EC - CERTIFICATE OF CONFORMITY
0432 - BPR - 210003807-1

In compliance with the Directive 89/106/EEC of the Council of European Communities of 21 December 1988 on the approximation of laws, regulations and administrative provisions of the Member States relating to the construction products (Construction Products Directive - CPD), amended by the Directive 93/68/EEC of the Council of European Communities of 22 July 1993, it has been stated that

the construction product
PHÖNIX PX1, PHÖNIX PX2, MEGAPHÖNIX MZP2N and MEGAPHÖNIX MZP2H
produced by the manufacturer

[Natural Smoke and Heat Exhaust Ventilator (NSHEV)]
E.M.B. Products AG
Kiesgräble 19
D-89129 Langenau

- has been submitted to a factory production control by the manufacturer
- and that the approved body - MPA NRW - has performed
- the initial type-testing of the product
- the initial inspection of the production site and of the factory production control and approval of the factory production control
- performs the continuous surveillance, assessment and approval of the factory production control

This Certificate of Conformity attests that all regulations concerning the performances described in Annex ZA of the standard

DIN EN 12101-2:2010 were applied. See enclosure of this Certificate of Conformity for the conditions laid down in the technical specification. The original of this document is valid.

Zulassungsstelle für Bauprodukte und Bauarten
Bautechnisches Prüfamt
Eine vom Bund und den Ländern
gemeinsam getragene Anstalt des öffentlichen Rechts
Mitglied der EOTA, der UEAtc und der WFTA

Geschäftszeichen:
II 16-1.10.1-561/1

Gültigkeitsdauer
vom: 31. Januar 2012
bis: 31. Januar 2017



Allgemeine bauaufsichtliche Zulassung

Zulassungsnummer:
Z-10.1-561

Antragsteller:
E.M.B. Products AG

Smoke and heat extraction systems by roda

We attach great importance to the high quality of all our products. All our smoke and heat extraction systems can also be used for everyday ventilation and stand out due to the following characteristics:

- Individually adaptable to all types of buildings
- Energy-saving natural lighting, which is glare-free when using opal polycarbonate or Lumira™-filled panels (light incidence from above is five times more effective than through side windows)
- All consoles are produced from high-strength castings
- Hail-and fall-through-proof depending on the specification
- Powder coating allows for individual choice of colours
- Plinth mounting using tension locks – no drill holes needed
- Flaps with fire-resistance rating A1 (depending on the specification)
- Low maintenance
- The products contain no harmful materials and can be recycled

Depending on the location and the requirements, the most suitable version can be chosen with regard to:

- Size
- Plinth mounting (EUROZARGE (frame) / EUROSOCKEL (plinth))
- Flange version (except VenturiSmoke)

In the event of fire, all NSHEVs with pneumatic drives open:

- Automatically via a thermal priority valve connected to a CO₂ cartridge
- Via an emergency fire control unit with a CO₂ cartridge
- Via a fire alarm control unit triggered by smoke detectors or actuator buttons (optional)

In the event of fire a smoke-and-heat-extraction-system control cabinet with backup batteries actuates the 24 V versions with servomotors:

- Via smoke detectors or actuator buttons (optional)
- Via an intermediate fire alarm control unit (optional)

Triggering for everyday ventilation via the building's compressed-air network, a ventilation control cabinet (pneumatic control), or a smoke-and-heat-extraction-system control cabinet (24 V servomotors):

- Ventilation control cabinet
- Actuator buttons
- Timer for night cooling (optional)
- Wind and rain sensors for protection against bad weather (optional)

Picture: MULTIJET and EUROLIGHT mounted together on the ridge of a gable roof



PHOENIX

In addition to its function as a natural heat and smoke extractor, the PHOENIX can be used for everyday ventilation; even coping with extreme weather conditions. On customer request the PHOENIX is available in insulated or non-insulated versions, or in the 33 version as a thermally separated system. The top flaps can be fitted with a choice of either 16 mm multiwall polycarbonate panels or an aluminium sandwich structure. Depending on the top flap infill, sound absorption levels of up to 33 dB RW are possible.

Depending on the design, the top flaps open via compressed air cylinders with end-position locking at both ends or via electric servomotors. Weathertightness is achieved by means of EPDM profile seals. On request, the PHOENIX can be supplied with fall-through-safety grids, thus helping to guarantee the required fall-through protection. Insect and bird screens are also available on request. The system modules are pre-assembled and tested ready for operation.

Advantages:

- Flexible sizing makes the system ideal for use on flat roofs for all roof openings up to 2.5 x 3 m²
- Suitable for everyday ventilation (full ventilation at 90° vent position)
- Endurance tests with 10,000 opening cycles have confirmed the robust, functional design and the high quality of the materials used
- The thermally separated version reduces condensation problems
- Good aerodynamic efficiency
- Good U-value and low joint leakage
- Available with opaque flaps
- Efficient drainage of rainwater via central drainage channels
- Maintenance-free hinges are aluminium castings with Teflon-coated bronze bushes and stainless steel shafts
- Easy mounting in all roof and wall constructions up to a 90° angle
- Device with EPDM gaskets, completely free of silicon.

The PHOENIX comply with DIN EN 12101-2 and VdS 2159 (depending on the specification).



In addition, the pneumatically controlled PX1 and PX2 units have been tested for explosion protection (ATEX) according to the EU Directive 94/9/EC with reference to EN 1127-1, EN13463-1 and EN 13463-5 (depending on system size and model). The EC declaration of conformity for the product and the explosion proofing are delivered with the product.

Field of application:

- Flat roofs
- Northlight roofs
- Skylight systems
- Gable roof skylight systems

Picture: A PHOENIX NSHEV unit on a large warehouse in Meco, Spain

PHOENIX

Versions:

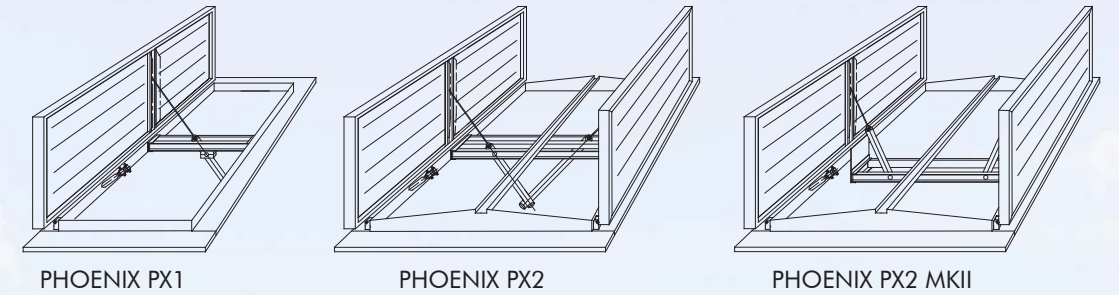

PX1G – Single-flap in an opening or a non-opening version (only for skylights/Northlight roofs)

PX2D – Double flap in opening or non-opening versions

PX2MKII – Double-flap version with short cylinders

Design characteristics:

The unit is made of AlMg3 aluminium alloy with single- or double-skin insulation. In the 33 version the thermal separation is achieved by using rolled-in polyamide bars for both the top flaps and the base. The heat loss is reduced to a minimum by EPDM seals. The maintenance-free pivot points on the cylinders or servomotors are made up of Teflon-coated bronze bushings with stainless-steel pins. Mounting on the plinth is by means of tension locks or screw connections with sealing washers.

Top flap versions:

- K2 - 16 mm clear polycarbonate panels (on request with Lumira™ insulation) or in opal, opaque or softlite
- K3 - 25 mm clear polycarbonate panels (on request with Lumira™ insulation) or in opal (only for the 33 version)
- A1 - Single-skin aluminium version
- A2 - Double-skin aluminium version (insulated)
- A3 - Double-skin aluminium version (thermally separated)

The top-flap frames are made of aluminium alloy (AlMgSi05). They are inclined at 6° to the horizontal. The top flaps are attached using three hinges with carriage bolts. All versions are available up to the maximum frame size.

Sizes:

The systems are made to order and can be produced in all lengths and widths up to 2,500 x 3,000 mm.

Large picture: PHOENIX NSHEV fitted at the end of a EUROLIGHT skylight



Thermally separated PHOENIX K33

Single-flap PHOENIX in a DELTALIGHT

PHOENIX on a flat roof

PHOENIX mounted on a EUROLIGHT

MEGAPHOENIX

The multifunction ventilator MEGAPHOENIX extracts natural warm air via two independently working pairs of double flaps. Rainproof ventilation is achieved via pneumatically or electrically controlled lateral flaps. The top flaps are controlled by pneumatic cylinders with end-position locking and a remote unlocking system or by electric motors. An automatic (independent from any other control system) thermal release mechanism is integrated to open the top flaps in the event of a fire. The aerodynamically formed top flaps and the inner side flaps are equipped with rubber seals. Fallthrough, Insect and bird screens are also available on request.

The MEGAPHOENIX complies with DIN EN 12101-2 and VdS 2159 (depending on the specification). The EC declaration of conformity is delivered with the product.



Field of application:

- Flat roofs
- Arched skylights
- Northlight roofs

Top flap versions:

The top-flap models available for the PHOENIX version are also available for the MEGAPHOENIX.

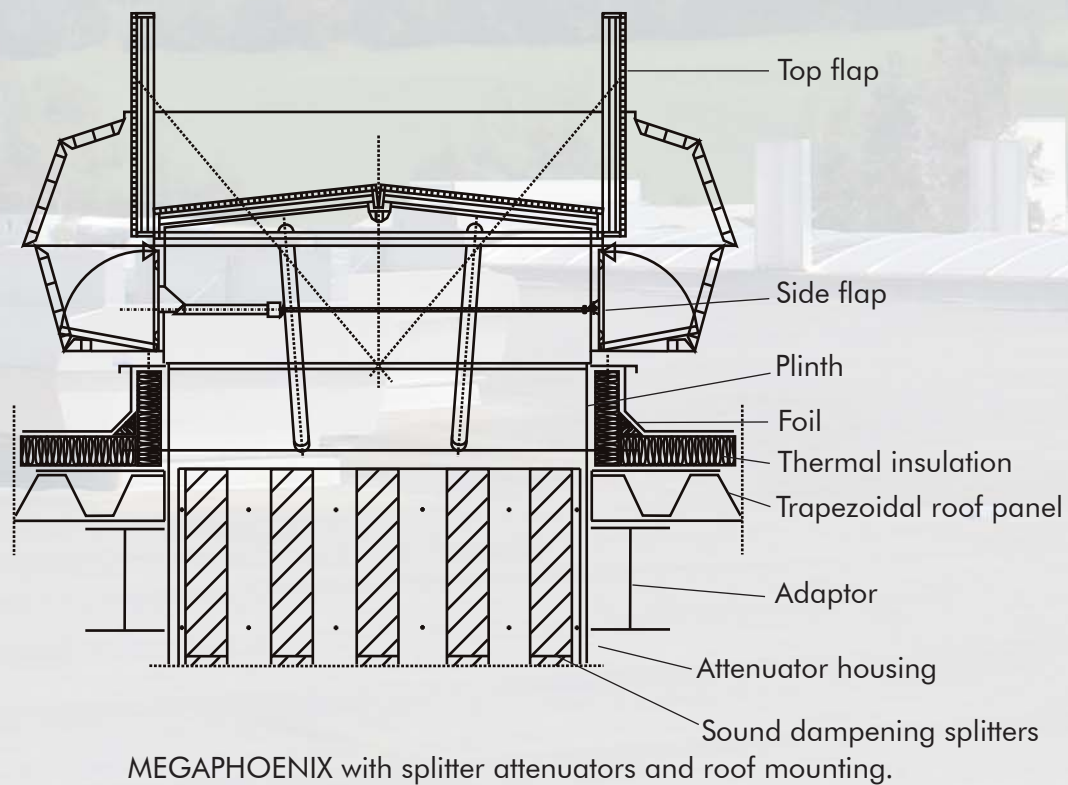

Sizes:

The MEGAPHOENIX can be produced in all lengths and widths up to 1,900 x 3,000 mm.



Large picture: MEGAPHOENIX as a stand-alone unit on a factory building



MEGAPHOENIX in a sloped roof



Flange-mounted on a skylight



MEGAPHOENIX on a skylight



The inside of a MEGAPHOENIX



VenturiSmoke VS2

The VenturiSmoke VS2 is a double flap that can be produced up to a size of 2.5 x 3.5 meters. The VS2 opens both in case of fire as well as for daily ventilation purposes with an opening angle of 90 degrees.

Depending on the model, opening panels open and close via compressed air cylinders with end position locking in both positions or via electrically operated actuators. Tightness is provided by EPDM profile gaskets. On request the VS2 comes with fall-through safety grids that meets the required fall-through safety regulations. Insects and bird screens are also available on request.

Advantages:

- Ideal for flat roofs with flexible construction sizes.
- Suitable for day-to-day ventilation (full ventilation at a 90° ventilation position)
- Endurance test with 10,000 opening cycles confirm the stability and functionality as well as the high quality of the materials used.
- A geometric opening area of 10 m² is feasible, when installed on a conical plinth.
- Aerodynamically effective opening area of up to 6.7 m².
- U-values up to 0,85 W/m²K are achievable with infills of up to 65 mm of thickness.
- Also available with dark flaps
- Efficient drainage of rain water via a central gutter
- All hinges are made of extruded profiles with stainless steel bolts and are therefore maintenance-free.
- Connection of drives is effected via Teflon-coated bronze bushings and is therefore maintenance-free.
- Can be delivered completely pre-mounted or in modules.
- Device with EPDM seals is completely free of silicon.
- The VenturiSmoke VS2 complies to the requirements of DIN EN 12101-2 (subject to model)

The VenturiSmoke VS2 comply with DIN EN 12101-2 (depending on the specification).



Field of application:

- Flat roof (up to roof areas with a maximum slope of 15°)



VenturiSmoke VS2

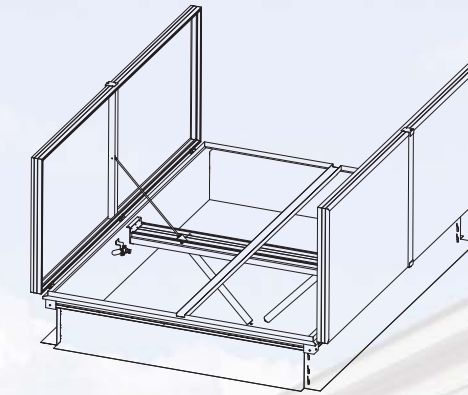

Unit base:

The plinth is part of the VS2 system and is tested as such. The traverse with the drives is screwed directly onto the base. The single-shell base made of AlMg Si05 alloy aluminium consists of a narrow frame with a rain gutter. EPDM seals reduce the leakage of hot air to a minimum. The drives' bearing points are made of Teflon-coated bronze bushings with stainless steel bolts and are maintenance-free.

Opening panel versions:

- K2 - 16 mm clear, opal, opaque or sofflite polycarbonate (available with Lumira™ - Insulation on request)
- K3 - 16 or 25 mm clear / opal polycarbonate
- K3 - 16 or 25 mm + 40 mm polycarbonate (U-value for the entire system up to 0,85 W/m²K)
- A1 - single-shelled aluminium
- A2 - double-shelled insulated aluminium
- A3 - thermally insulated aluminium with 20- or 30-mm insulation.

The opening panel frames are made from AlMg Si05 alloy aluminium. They are fixed at three hinges by means of locking screws. The frames of opening panel version 33 are thermally separated via rolled in polyamide bars. All opening panel variants are approved up to the maximum construction size.

Drives:

Opening panels are driven by choice either electrically via linear actuators or pneumatically via cylinders with end position locking in both positions.

Plinths:

The system is tested and approved with straight and conical plinth with a height of 350- and 450-mm. Plinths of other makes are permitted, as far as they correspond to the aerodynamic requirements with respect to:

- Design (in compliance with the geometric specifications)
- Size

Sizes:

The systems can be produced in all conceivable length and width up to a size of 2,500 x 3,500 mm, as these are manufactured on customer's order.

Large picture: The natural smoke and heat extractor VenturiSmoke VS2 in daily ventilation modus



90° opening panel position for ventilation



Hinges designed for daily ventilation



Plug-in plinth before gluing-in



Traverse mounted directly on a plinth

FIREFIGHTER

The FIREFIGHTER natural smoke and heat exhaust ventilation system meets the standards of preventive fire protection according to EN 12101-2 and VdS 2159. The ventilator meets very high standards regarding stability and sound insulation. The unit base and top-flap construction is made of AlMgSi05F22 with integrated thermal separation. There are three flap versions available: aluminium sandwich sheets, insulated glass or polycarbonate. The versions A33 / G33 are thermally broken according to DIN 4108.

Equipped with weatherproof profiled seals between the unit base frame and the top flaps, the units are manufactured with an integrated rainwater drainage system. For higher safety standards the base frames and the top flaps are manufactured from non-combustible materials according to DIN 4102. If required, the FIREFIGHTER can be delivered with fall-through-safety grids to guarantee the required fall-through protection. The units are tested and delivered ready for use.

Advantages:

- Flexible sizing makes the system ideal for use on flat roofs for all roof openings up to 4.75 m² (Duo version) or 3.75 m² (Delta version)
- Suitable for everyday ventilation (full ventilation at 90° vent position)
- High sound absorption characteristics up to 56 dB
- Thermal separation in accordance with DIN 4108 (depending on the specification)
- Endurance tests with 10,000 opening and closing cycles have confirmed the robust design and high quality of the materials used.
- Good aerodynamic efficiency
- Good U-value and low joint leakage
- Available with opaque flaps
- Maintenance-free hinges made of cast aluminium parts with Teflon-coated bronze bushes and stainless steel shafts
- Efficient drainage of rainwater via central drainage channels

The FIREFIGHTER complies with DIN EN 12101-2 and VdS 2159 (depending on the specification). The EC declaration of conformity is delivered with the product.



Field of application:

- Flat roof
- Gable roof
- Pent roof
- Pent-roof skylight
- Gable-roof skylight
- Northlight roof

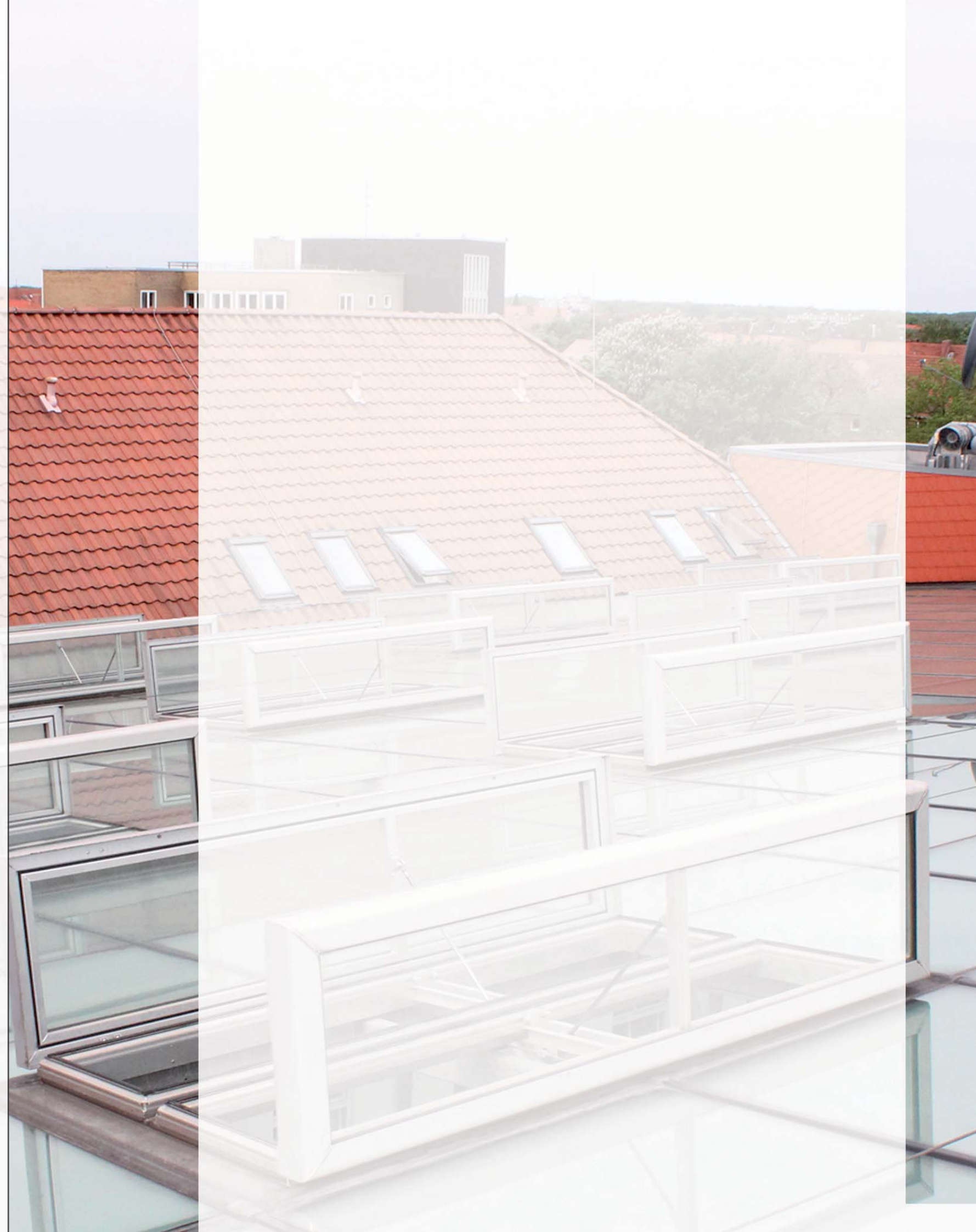

FIREFIGHTER

The FIREFIGHTER DUO with horizontal top-flaps is available in two models; model 22 (no thermal separation) or model 33 (thermally separated). The FIREFIGHTER DELTA with inclined top flaps at a 30° angle is only available in the thermally separated version.

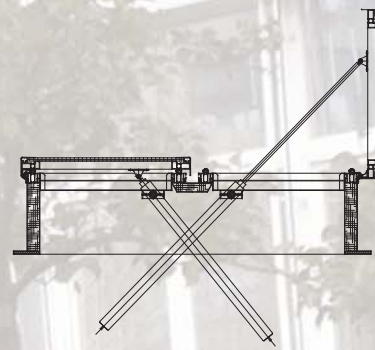

FIREFIGHTER DUO

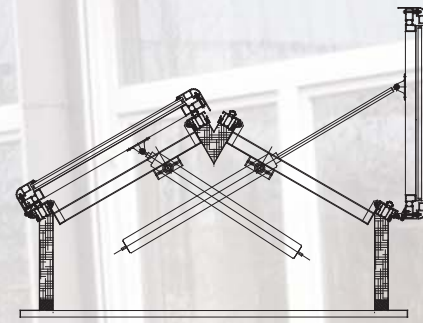

FIREFIGHTER DELTA

Top-flap versions for model 22:

- 16 mm multiwall polycarbonate panels, clear (Lumira™ insulation on request) or opal
- any safety glass and glass for special requirements on request (fire-resistance rating A1)
- A2 – double-skin aluminium (50 mm insulated)

Top-flap versions for model 33:

- 16 mm multiwall polycarbonate panel, clear (Lumira™ insulation on request) or opal
- any safety glass and glass for special requirements on request (fire-resistance rating A1)
- A2 double-skin aluminium (50 mm or 70 mm insulation)

Design characteristics:

The maintenance-free pneumatic cylinders lock in the open and closed position to withstand pressures $> 500 \text{ N/m}^2$ and suction forces $> 1500 \text{ N/m}^2$. In the event of a fire, on reaching a temperature of $68 \text{ }^\circ\text{C}$, the thermal priority valve is activated via a CO_2 cartridge and the pneumatic cylinders open the top flaps. Alternatively, the top flaps can be opened by electric motors. The system can be remotely activated by a central control system. The equipment is delivered on site, preassembled and quality tested by the manufacturer, ready for installation. The construction is connected to the metal mounting frame with burglarproof tension locks. All pivot points are equipped with (maintenance free) Teflon-coated bronze bushes and stainless steel shafts.

Sizes:

As the FIREFIGHTER systems are made to order, they can be produced in all lengths and widths up to $1,900 \times 2,500 \text{ mm}$ (Duo version) and $1,500 \times 2,500 \text{ mm}$ (Delta version).



Large picture: FIREFIGHTER DELTA as a natural and heat extractor for the ground floor



Mounted on a sloped plinth



Stand-alone unit with aluminium top flaps



FIREFIGHTER DUO with insulated glass



Combined with a glass skylight



SMOKEJET

The SMOKEJET is a louvred ventilator for natural ventilation and smoke and heat extraction. It is a maintenance-free, compact and lightweight unit available with a variety of control options and finishes to suit all industrial and most commercial applications. The ventilator side panels are reinforced by internal longitudinal sections. The unit is made from corrosion-resistant aluminium alloy, AlMg3. Controlling the louvers takes place optionally electrically by means of a linear spindle actuator, pneumatically by means of a cylinder alternatively with an one pipe system (pressure to open/ close by spring) or a two pipe system (pressure to open / pressure to close), or via a pressure spring release device (DFA). To enable the ventilation function, this is used in conjunction with a pneumatic drive (PDFA) or an electric drive (EDFA). The louvre blades can be made of glass, polycarbonate or aluminium. Due to the variable unit dimensions and the adaptor flange range, the SMOKEJET can be easily installed in all customary roof and wall constructions, also as a natural ventilation and smoke extraction system. Insect and bird screens are available on request.

Advantages:

- Ideal for use on Northlight roofs and roofs with an inclination of 30° to 90°, as well as in walls
- Individual customisation for all roof openings up to 5.71 m²
- Suitable for everyday ventilation (full ventilation at a louvre position of 90°)
- Only one drive per unit necessary
- The pneumatic or electric drive is completely hidden inside the frame
- Only one control cable necessary
- Good aerodynamic efficiency
- Channels in the louvre blades conduct rainwater into a lateral drainage channel and prevent it from entering the building

The SMOKEJET complies with DIN EN 12101-2 and VdS 2159 (depending on the specification). The EC declaration of conformity is delivered with the product.



Field of application:

- Flat roofs
- Skylight systems
- Northlight roofs

Picture: SMOKEJET with polycarbonate louvre blades integrated in a glass skylight



SMOKEJET

Sealing brushes or EPDM seals reduce the leakage of warm air is to a minimum. The louvre hinges are made of aluminium and pivot in UV resistant nylon bushes.

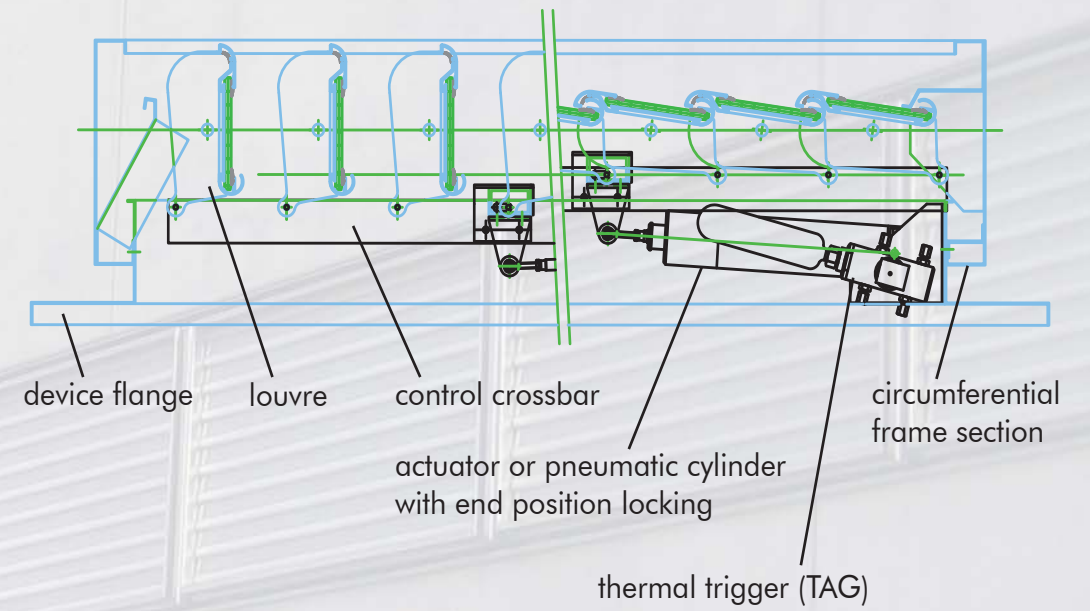

Louvre blades:

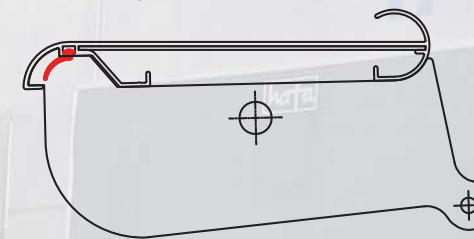

A1 – Single-skin aluminium louvre blade

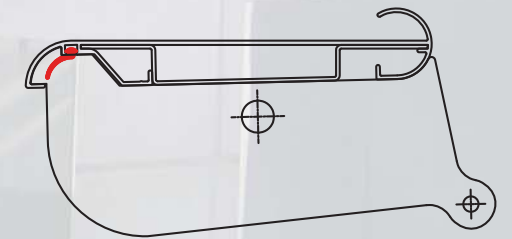

A2 – Double-skin aluminium louvre blade

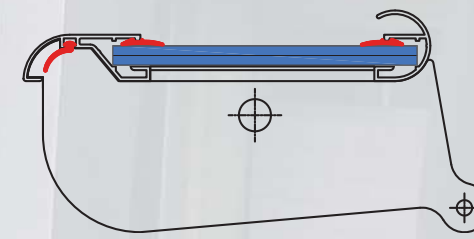

GL – Single-skin LSG glass louvre blade

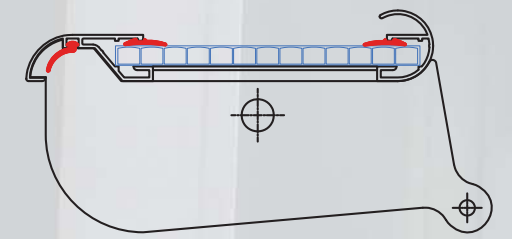

PC - louvre blade in the variants 8 mm and 8 + 8 mm (shown here 8 mm)

Sizes:

The units can be produced in all widths and defined lengths up 2,226 x 2,966 mm. The length results from the width of the individual louvre blades: 133 mm (Length = number of louvre blades x 133 mm + 40 mm for the frame).

Large picture: SMOKEJET as an air supply unit in the wall



SMOKEJET for inlet air

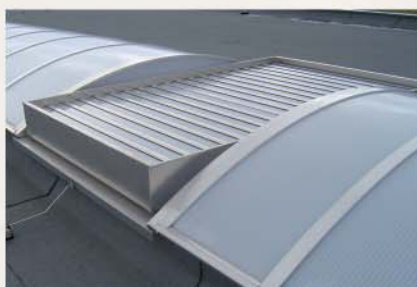

Installed in a EUROLIGHT



SMOKEJET in vertical glazing



Connected to a trapezoidal gable roof

MULTIJET

The MULTIJET is an all-weather version of the SMOKEJET, the difference being the modified frame with lateral ventilation flaps (comparable with MEGAPHOENIX and MEGASTAR), which provide for good ventilation even in bad weather. The lateral flaps are also opened pneumatically or electrically as soon as the upper louvre blades close due to rain. The closing mechanism consists of two springs. The MULTIJET also serves as natural smoke and heat exhaust ventilator. It is the only officially approved multi-purpose ventilator for use not only on horizontal roofs, but also on inclined roofs such as Northlight roofs.

As is the case for all the other systems, the MULTIJET complies with DIN EN 12101-2 and VdS 2159 (depending on the specification). The EC declaration of conformity is delivered with the product.



Field of application:

- Flat roofs
- Arched skylights
- Northlight roofs

Model versions:

The same louvre blades are available for the MULTIJET as for the SMOKEJET. The inner flaps are generally 160 mm high and 120 mm long.

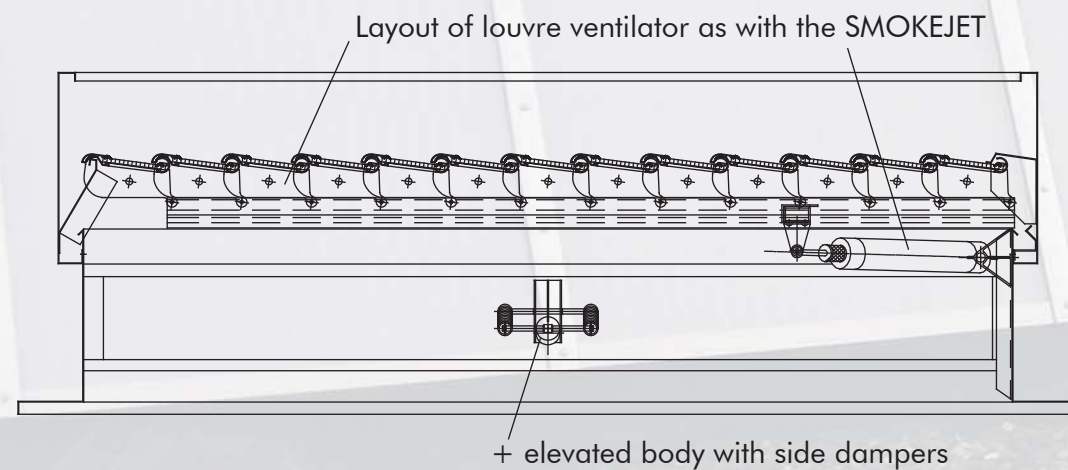

Sizes:

The MULTIJET can be produced in widths and defined lengths up to 1,926 x 2,966 mm. As is the case for the SMOKEJET, the lengths are determined by the louvre width of 133 mm. (Length = number of louvre blades x 133 mm + 40 mm for the frame).



Large picture: MULTIJET with polycarbonate louvre blades mounted in DELTALIGHT skylight system



Stand-alone unit on a factory roof



MULTIJET mounted on a EUROLIGHT



MULTIJET mounted in a DELTALIGHT



On a gable roof ridge



VenturiSmoke

VenturiSmoke is a natural smoke and heat extraction system (NSHE), which complies with the European Standards. It features an opening panel, that opens to an angle of 165° in case of fire. The drive unit technology can either be pneumatic (cylinder) or electric (48V drive). Both functions, OPEN and OPEN/SHUT can be respectively assigned to the compressed air cylinder. For day-to-day ventilation the pneumatic version can be additionally equipped with a 230V electric drive, which opens with an upstroke of 300 mm. The 48V version's drive can also be used for daily ventilation.

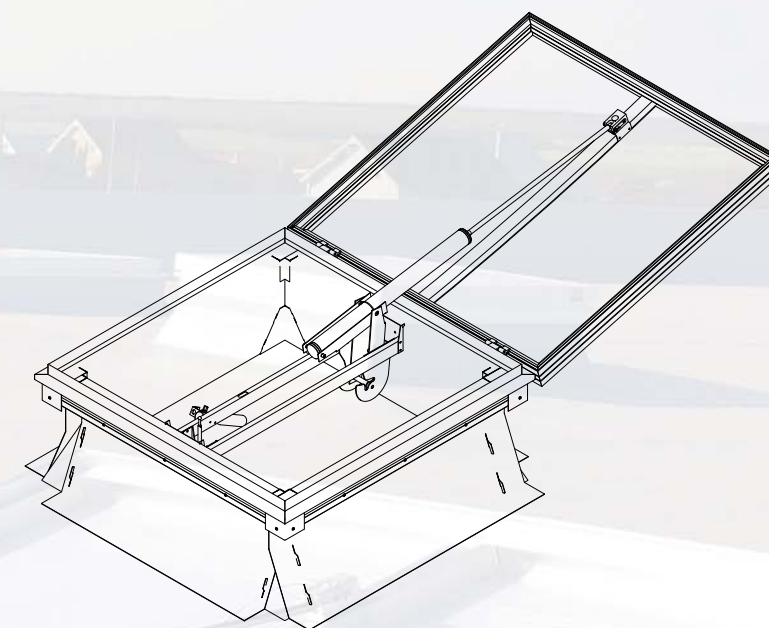

VenturiSmoke with pneumatic drive

Benefits:

- Ideal for flat roofs with flexible construction sizes of up to a roof opening of 2 x 2 meters.
- Suitable for day-to-day ventilation, subject to model
- Durability tests of 10,000 open/close cycles certify the stability and functionality of the design as well as the high quality of the materials used.
- Good aerodynamic effectiveness
- For daily ventilation the 48V drive allows for adjusting individual opening angles to a maximum of 165°
- Also available with dark flap
- Available with thermally separated flaps.
- Energy saving, natural illumination, which becomes glare-free, when opal, sofflite or Lumira-filled polycarbonate multi-wall panels are used for the opening panel infill. (Illumination from above is five times more effective than from the sides.)
- Fall-through safe, subject to model
- Fire classification A1, subject to model
- Delivery of the systems either pre-mounted and ready-for-use or in modular design

The systems comply to the requirements according to EN 12101-2.



Picture: VenturiSmoke opened 165° for smoke- and heat exhaust



VenturiSmoke

Application:

- flat roof (up to a maximum roof pitch of 15°)

Variants:

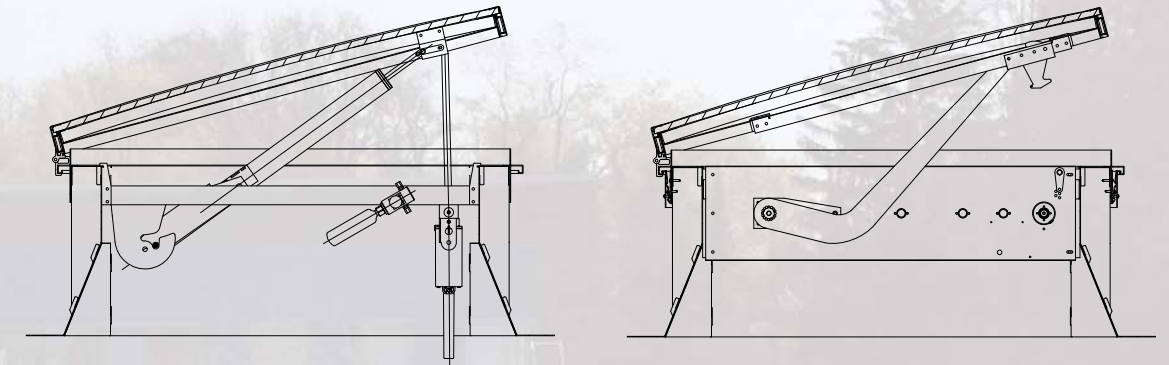

Pneumatic drive with 230 V motor for ventilation

Electric drive for adjusting individual ventilation preferences

Construction features:

The VenturiSmoke is made from aluminium alloy AlMg3, AlMgSi05F22 and steel parts. EPDM seals reduce the loss of warm air to a minimum. All pivot points are maintenance free. Optionally, the VenturiSmoke can be fitted with anti-fall grids, which meet the demanded fall through safety standards. All systems can be delivered either pre-mounted and ready-to-use or in modular design.

Opening panel infill:

- A1- single-skinned aluminium
- A2- double-skinned aluminium (insulated)
- A3- double-skinned aluminium 20 or 30 mm (insulated and thermally separated)
- K2- 16 mm polycarbonate
- K3- 16 mm / 25 mm polycarbonate (thermally separated)

Construction sizes:

Due to the size of the traverse, the roof opening width is restricted to the following dimensions: 1000, 1200, 1250, 1400, 1500, 1800 and 2000 mm. The roof opening length, however, can be built in all conceivable dimensions between 1000 and 2000 mm.

Picture: VenturiSmoke VS1 on a food company's roof, opened for daily ventilation



Powerfull 48V opening system



Pneumatic drive with one cylinder



Separate drive for daily ventilation



Plug-in plinth before gluing-in

Roof mounting (frame/plinth)

Together with the customer we choose the correct material, the mounting system and the unit height depending on the roof design and the operating conditions. On a flat roof, for example, stand-alone units have to be mounted on a plinth. Roof lights are also mounted on a frame, which due to its length has to be reinforced by stiffening bars at specified intervals. Units that are mounted, for example, on a Northlight roof or on the ridge of a gable roof are, however, mounted using customised flanges.

Installation using a EUROSOCKET (plinth) / EUROZARGE (frame)

Principally, there are two main versions; the EUROSOCKET for installing on flat roofs and the EUROZARGE for installing on continuous skylight systems and integrated systems. The plinths and frames are designed to allow an 80 mm external insulation layer, which can be applied by the roofer using foil, bituminous sheets or sheet metal. The standard height of the EUROSOCKET and EUROZARGE units is 350 mm. However, depending on the type of installation and the drainage characteristics of the roof, plinth heights between 150 and 500 mm are possible.

Advantages:

- Adaptable to all types of roofs
- Non-combustible as part of preventive fire prevention measures
- Available in different heights
- Available in different material thicknesses depending on the structural requirements
- Available in a screw or a latch version
- Thermally insulated or thermally separated depending on the version
- Direct mounting on a truss-and-purlin roof
- Simple mounting, as no additional surrounding frames are necessary
- Powder coating allows individual choice of colours

Installation using a flange

When installed on Northlight roofs, gable roofs or in a vertical position, the units can be fitted directly to the roof without problem due to the favourable installation situation. Five different flange versions are available. If none of these versions is suitable, a custom design can be realised.

Fall-through protection

All NSHEVs, plinths and frame constructions can be fitted with fall-through protection. These fall-through-safety grids are either ready mounted or are fitted to the EUROSOCKET.

Further information on these subjects can be found in our brochure „Roof-mounting & Fall-through-safety Systems“!





A MEMBER OF LAMILUX GROUP

